

- PLURIMATERICITA' DELLE COMPONENTI.

- NON RICICLABILITA'.

- NECESSITA' DI MOLTEPLICI SOLUZIONI PER L'ESPOSIZIONE E LA DISTRIBUZIONE.

- UTILIZZO DI MATERIALI NON RICICLATI.

- ELEVATI INGOMBRI.

OPS!

- MONOMATERICITA'.
- TOTALE RICICLABILITA'.
- UTILIZZO DI CARTONE RICICLATO.
- SOLO 2 COMPONENTI PER LA REALIZZAZIONE.
- UNICO ELEMENTO PER ESPOSIZIONE E DISTRIBUZIONE.
 - RIDUZIONE DEL PESO.
 - RIDUZIONE DEI VOLUMI.

OPS!: CONTENITORE – ESPOSITORE PER ANELLO

Dimensioni: 5 cm x
5 cm x 2,5 cm

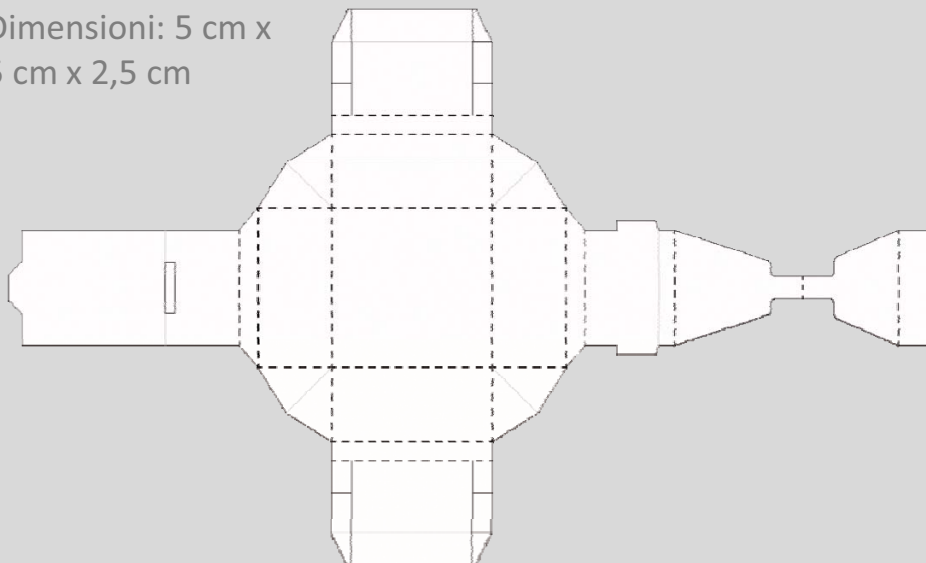

OPS!: CONTENITORE – ESPOSITORE PER BRACCIALE

Dimensioni: 7 cm
x 9 cm x 2,5 cm

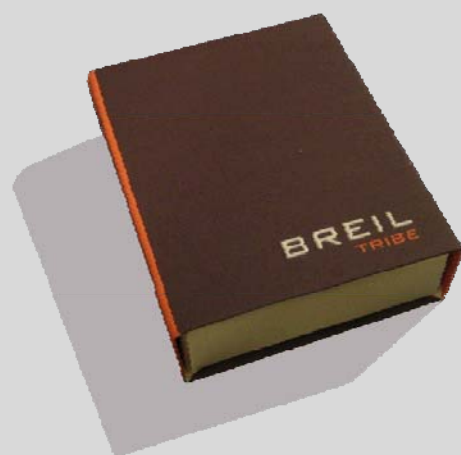
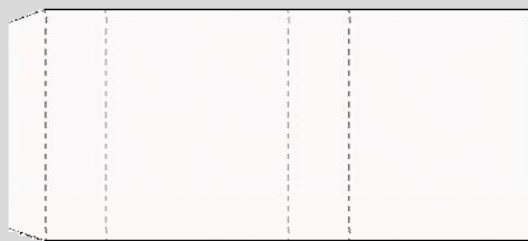
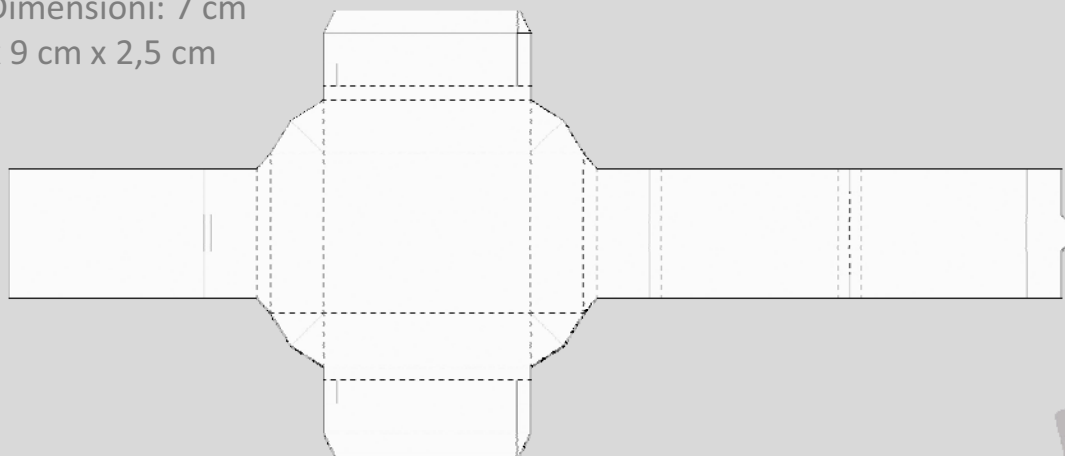

OPS!: CONTENITORE – ESPOSITORE PER ORECCHINI

Dimensioni: 7 cm
x 9 cm x 2,5 cm

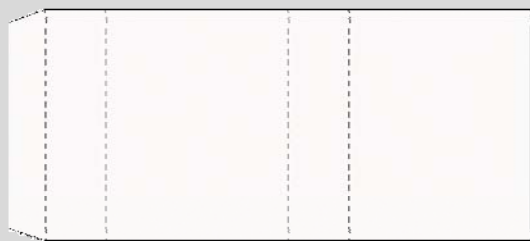
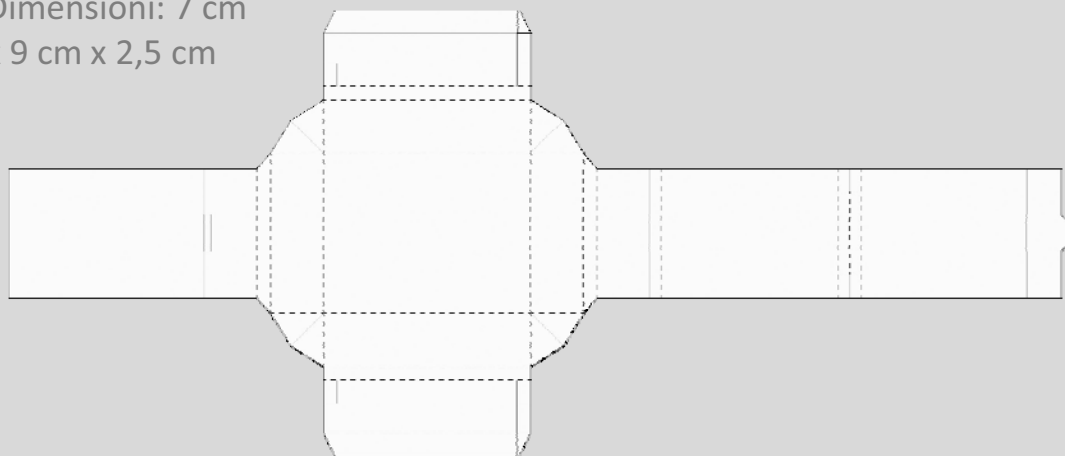

OPS!: CONTENITORE – ESPOSITORE PER COLLANA

Dimensioni: 27 cm
x 10 cm x 2,5 cm

